

# HUSSMANN®

*Island Merchandisers*

ISMGG/ISFGG/ISCGG



ISMGG

# ISMGG/ISFGG/ISCGG

## Island Merchandisers with straight Glass on all 4-sides

ISMGG Medium Temperature and ISFGG Frozen Food Models available in 5' and 10' Lengths.

ISCGG Ice Cream Model available in 5' Length only.

# HUSSMANN®

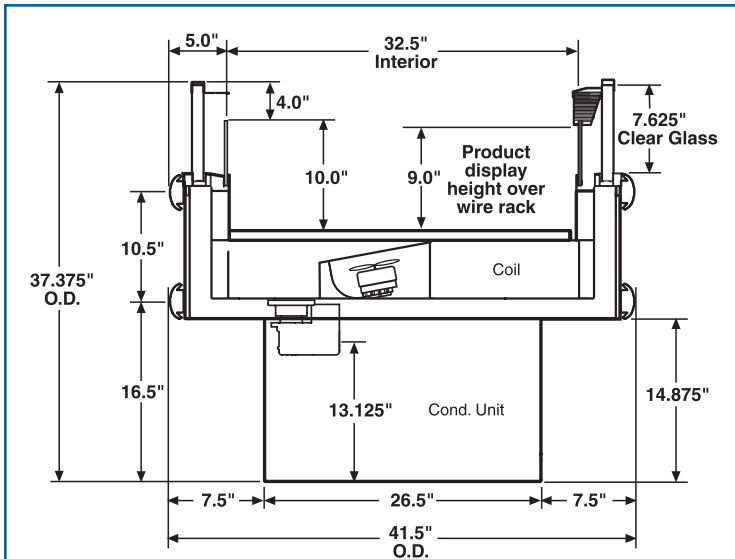

**Note:** Each 5-foot case section has a full 60" of interior length for product display.

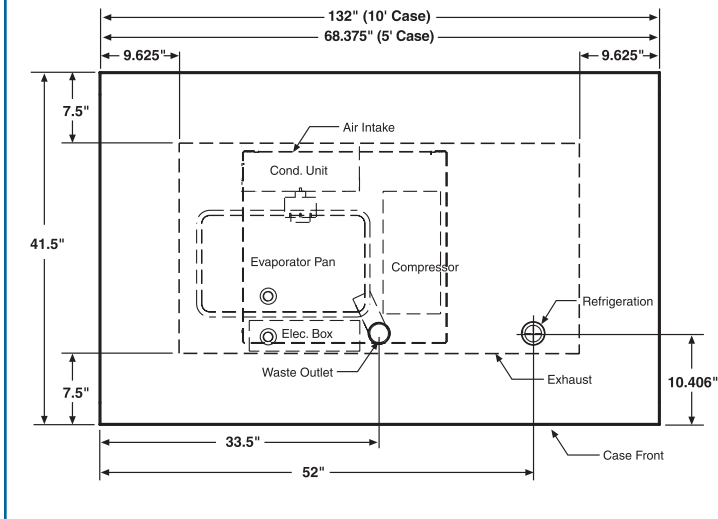

**NOTE:** For optimum performance, these models are designed for use in air-conditioned stores where temperature and humidity are maintained at 75°F and 55% R.H. Locate case away from direct sunlight, rapid air currents and extreme temperature changes.

We reserve the right to change or revise specifications and product design in connection with any feature of our products. Such changes do not entitle the buyer to corresponding changes, improvements, additions, or replacements for equipment previously sold or shipped.



### Standard Features

- White Powder Coated Interior Paint
- Black Upper and Lower Impact Bumpers
- R-22 Refrigerant (Except ISCGG Model which is R-404A)
- Digital Fahrenheit Thermometer
- Telescoping Bottom Wire Shelves
- Adjustable Temperature Control
- Condensate Pan
- Expansion Valve with Filter Kit
- Anti-Sweat Heater Kit



### Optional Accessories

- Dual Temperature Kit Changes Merchandiser to Medium Temperature and is Available on Frozen Food and Ice Cream Models
- Variety of Color Options for Bumper and Décor Panels
- Stainless Steel Exterior
- High Humidity Condensate Pan Kit (most models)
- Price Tag Moulding
- Energy Efficient Fan Motor Kit
- Duplex Receptacle Kit
- Recessed Casters
- Scale Hanger and Bag Holder
- Variety of Alternate Thermometers

**Note:** All 10' models have two separate refrigeration systems.

### Warranty

Five years against insulation failure or leaks in insulated area. Five years against failure of compressor. One year against defective materials or faulty workmanship, including labor.

Web Site: [www.hussmann.com](http://www.hussmann.com)  
1-800-922-1919