

# HUSSMANN®

HGL-2BS

Self Contained Vertical Glass Door Merchandiser for  
Frozen Food and Ice Cream



# Self-Contained HGL Vertical Glass Door Merchandisers



HGL-1BS, HGL-2BS, HGL-3BS Bottom Mount Low Temperature for Frozen Food and Ice Cream

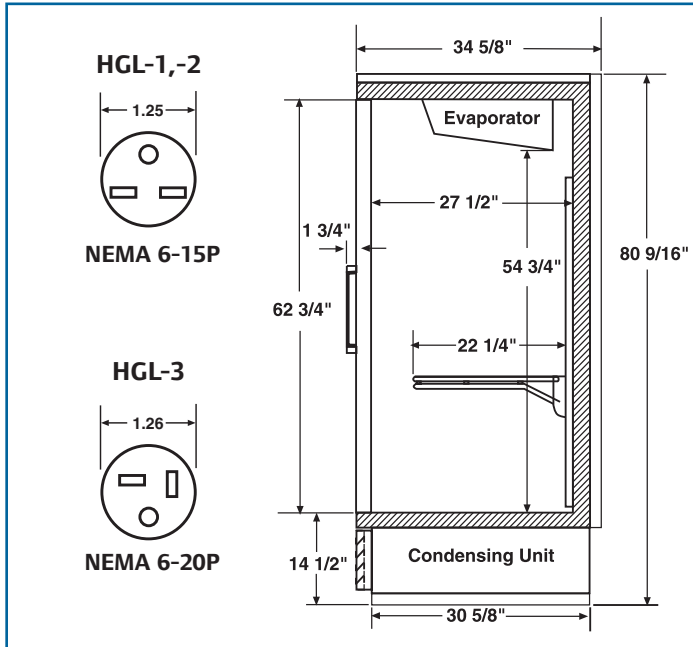

## Standard Features

- Contemporary styling of the Accent Series places maximum attention on merchandising. All Accent Series merchandisers have the same access panel design for commonality between merchandisers.
- Product visibility is improved with 60" long vertical T-8 lighting and electronic ballasts. Merchandise is evenly illuminated throughout display area. More lights per merchandiser with two lights in single-door, three-lights in two-door, and four lights in three-door models.
- White powder coated exterior and interior finish.
- CFC-Free refrigerant R-404A and CFC-Free foamed-in-place urethane insulation.
- Doors can be locked open for stocking.
- Each door section includes four adjustable cantilever-type shelves and a bottom rack. All shelves and racks have a white epoxy coated finish. Shelves may be slanted for special displays and are interchangeable in all models.
- Full use of the shelf upright posts is available for positioning the shelves. Shelf bracket profiles have been slimmed down to better facilitate product merchandising under and across the shelves.
- Low temperature HGL models are equipped with a single 230-volt power cord attached (see diagram).
- Balanced refrigeration system provides maximum efficiency and energy savings. Includes thermostat-controlled automatic defrost.
- Easy-to-read digital solar powered thermometer. Electronic temperature control insures consistent product temperature.

## Optional Accessories

- Variety of Exterior Colors
- Three Tier Step Rack
- Price Tag Moulding
- Baskets
- Door Guard
- Leveler Kit
- Peg Bar and Hooks
- End Windows
- Lighted Sign
- Shelf Product Stops
- Additional Display Shelves
- Caster Kit

## HGL-BS Optional Lighted Sign



NOTE: For optimum performance, these models are designed for use in air-conditioned stores where temperature and humidity are maintained at 75°F and 55% R.H. Locate case away from direct sunlight, rapid air currents and extreme temperature changes.

We reserve the right to change or revise specifications and product design in connection with any feature of our products. Such changes do not entitle the buyer to corresponding changes, improvements, additions, or replacements for equipment previously sold or shipped.

## Matching Medium Temperature Models

For a matching side-by-side display of dairy, deli, beverages and wine, be sure to see the companion HGM-BS series of medium temperature 1-, 2-, and 3-door models.

## Warranty

Five years against insulation failure or leaks in the insulated area. Five years against failure of compressor. One year against defective materials or faulty workmanship, including labor.

Model	Cu.Ft Cap.	Doors	Dimensions (Inches)						Electrical					Ship Wt.	
			Outside			Inside			Unit H.P.	HZ/PH	Volts	Fuse Size	Power Cord		NEMA Plug Nos.
			L	W*	H**	L	W	H							
HGL-1BS	22.2	1	287/8"	345/8"	809/16"	24"	271/2"	623/4"	3/4	60/1	208/230	15 amp	Yes	6-15P	667
HGL-2BS	44.3	2	52"	345/8"	809/16"	48"	271/2"	623/4"	1	60/1	208/230	15 amp	Yes	6-15P	936
HGL-3BS	66.1	3	753/8"	345/8"	809/16"	711/4"	271/2"	623/4"	1 1/2	60/1	208/230	20 amp	Yes	6-20P	1225

\*Exclusive of door handles. All use R-404A Refrigerant. \*\*Optional lighted sign increases overall height to 83 9/16".



**HUSSMANN®**

Web Site: [www.hussmann.com](http://www.hussmann.com)

Hussmann Corporation

140 E. State Street  
 Gloversville, NY 12078  
 (518) 725-0644  
 (800) 753-7790  
 Fax: (518) 725-3801

