

HUSSMANN®

DDSS-4D/G

Narrow Footprint Multi-Deck Merchandiser

Versatile merchandiser with 26" depth is ideal for applications that require maximum product facings with a minimum of floor space used



Shown With Optional Lighted Sign

DDSS-4D/G

Narrow Footprint Multi-Deck Merchandiser

Versatile merchandiser with 26" depth is ideal for applications that require maximum product facings with a minimum of floor space used

HUSSMANN®

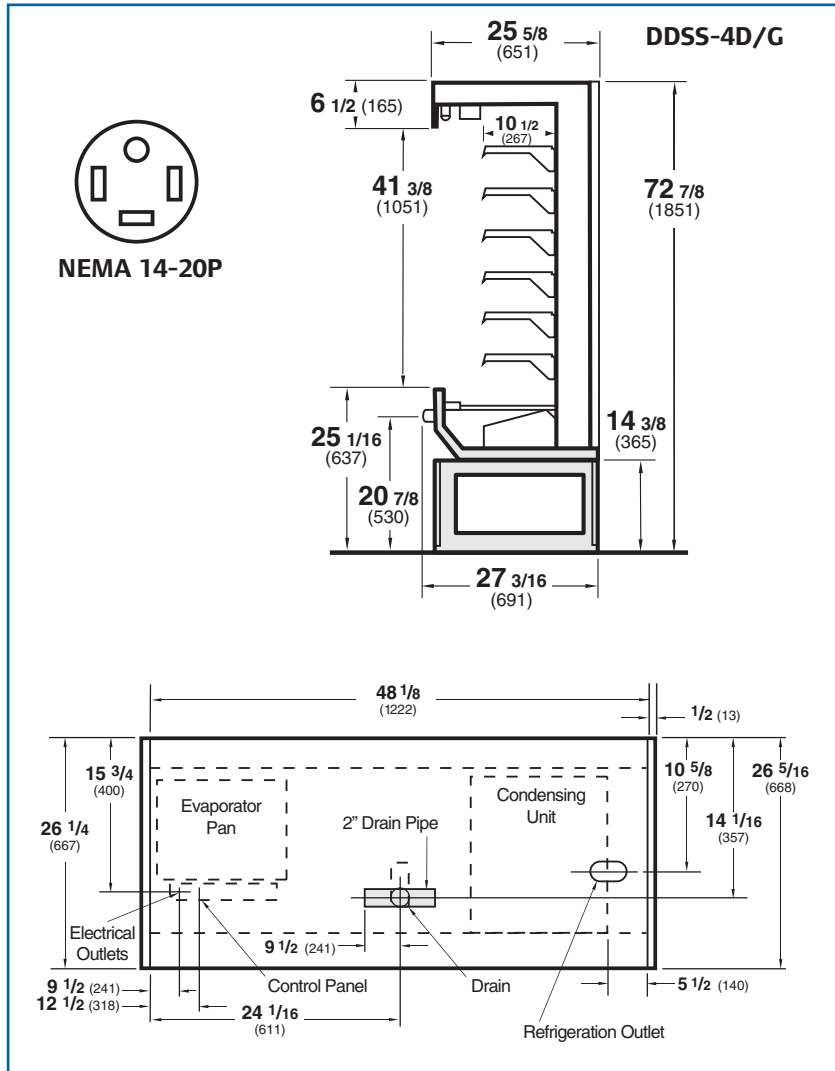

Standard Features:

- 6 Rows 9-3/4" Glass Shelves
- High Humidity Condensate Pan
- 8-Foot Power Cord (Packed Loosed)
- Full Glass Ends With White Frit
- 1-Row Upper Canopy Light (T-8)
- Black Front Bumper
- Silver PTM
- White Painted Interior & Exterior
- Bottom Display Deck
- Safe Net Control and Temperature Display

Optional Accessories

- Lighted Sign (44" L x 5-1/4" Available for Graphic Display)
- Low Profile Casters
- 12" Solid Metal Shelves (Unlit)
- Solid Ends
- Gold PTM, Black PTM, White PTM
- Optional Color Front Bumper (Pearl, Red, White)
- 1-1/2 Plex Product Stop
- One End Off for Joining 2 Units
- 10-1/2 Plex Partition & Joint Kit (for Joining 2 Cases)
- Remote Less Unit
- Stainless Steel Exterior
- Optional Exterior Color Selection
- Black Frit on End Glass
- Black Painted Case Interior

Warranty

Five years against insulation failure or leaks in insulated area. Five years against failure of compressor. One year against defective materials or faulty workmanship, including labor.

Web Site: www.hussmann.com
1-800-922-1919



Model	Exterior Dimensions			Nominal H.P.	Refrig.	Hz/Ph	Volts	Electrical			Approx. Ship Wt. (Lbs.)
	L*	D**	H					Run Amps	Fuse Amps	NEMA PLUG	
DDSS-4	49 7/8"	26"	72 7/8"	-	R-22	60/1	125/208-230	-	-	14-20P	890

* With Glass Ends **Not Including Front Bumper

These merchandisers are designed for use in stores when temperature and humidity do not exceed 75°F and 55% RH.

We reserve the right to change or revise specifications and product design in connection with any feature of our products. Such changes do not entitle the buyer to corresponding changes, improvements, additions, or replacements for equipment previously sold or shipped.



Hussmann Corporation
140 East State Street
Gloversville, NY 12078
(518) 725-0644
Fax: (518) 725-3801