

HUSSMANN®

DCSG-12

Ice Cream Dipping Display Merchandiser



Ice Cream Dipping Display Merchandiser

HUSSMANN®

DCSG-4, DCSG-8, DCSG-12, DCSG-16, DCSG-8-D, DCSG-12-D, DCSG-16-D

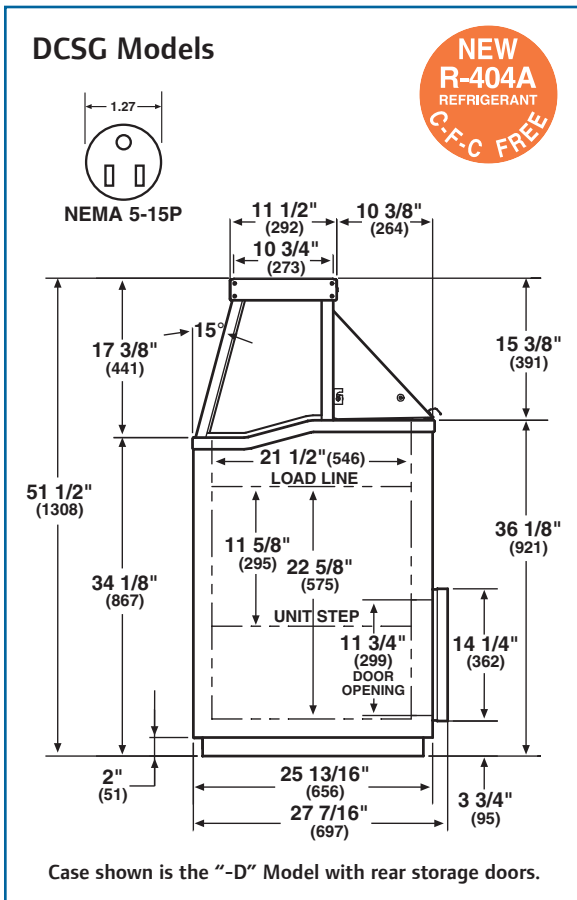

NOTE: These merchandisers are designed for use in stores when temperature and humidity do not exceed 75°F and 55% RH.

We reserve the right to change or revise specifications and product design in connection with any feature of our products. Such changes do not entitle the buyer to corresponding changes, improvements, additions, or replacements for equipment previously sold or shipped.

Specifications

	Capacity		No. Lids	Dimensions					Unit H.P.	Electrical - 60 Hz				Ship Wt.
	9 1/2" Dia. 3-Gal. Cans			Exterior			Interior			Volts	Run Amps	LRA Amps	Fuse Amps	
	Display	Storage		L	W	H	L	W						
DCSG-4	4	0	1	25 3/8"	25 13/16"	51 1/2"	21"	21 1/2"	1/3	115	6.9	33.0	15	250
DCSG-8	8	4	1	47 7/16"	25 13/16"	51 1/2"	43 7/8"	21 1/2"	1/2	115	9.5	58.0	15	405
DCSG-12	12	8	2	67 5/16"	25 13/16"	51 1/2"	63"	21 1/2"	1/2	115	9.9	45.0	15	515
DCSG-16	16	12	2	87 7/16"	25 13/16"	51 1/2"	83 1/8"	21 1/2"	3/4	115	10.5	59.8	15	625

"-D" Models with Rear Storage Doors

For easy "in and out" of tubs without disrupting service to customers. (Not applicable to DCSG-4)



Web Site: www.hussmann.com

Design

Contemporary new design complements the new ACCENT SERIES™ merchandisers. Maximum attention placed on product visibility by lowering the merchandiser front 2". Improved lid pivot design and lid gasketing.

Display

Interior canopy light provides added illumination of product display. Optional canholder trays have been designed to slightly slant towards the front of the merchandiser to improve product visibility and access for easier ice cream dipping.

Refrigeration

All models feature R404A CFC-free refrigerant. Rear air intake and discharge allow front and sides of merchandiser to be built into a fixed counter area. Merchandisers can be converted to rear air intake and front air discharge if required. Condensing unit access panel design facilitates maintenance and service. Improved access to temperature control and on/off power switch. Equipped with 115 volt, 15 amp power cord.

Warranty

Five years against insulation failure or leaks in insulated area. Five years against failure of compressor. One year against defective materials or faulty workmanship, including labor.

Optional Accessories

- Dipper Well
- Choice of Exterior Colors
- Lid Lock Kit
- Glass Canopy Ends
- Caster Kit
- Night Cover for Case Opening
- Six-Inch Leg Kit
- Frost Shields
- Flavor Tabs



Optional Gelato Pan Racks

Optional Display Kits

Now available... a choice of two different ice cream canholder kits and a Gelato kit so you can choose the display accessories that best fit your needs.



Canholder Kit with Side Rails



Canholder Kit - New Style with Plastic Hood and Wire Rack System

