

# HUSSMANN®

USL-2

Self Contained Upright Storage Freezer



# Self-Contained USL Upright Storage Freezer



USL-2

Ideal for Convenience Stores, Ice Cream Parlors, Restaurants, Institutions and other Service Centers.

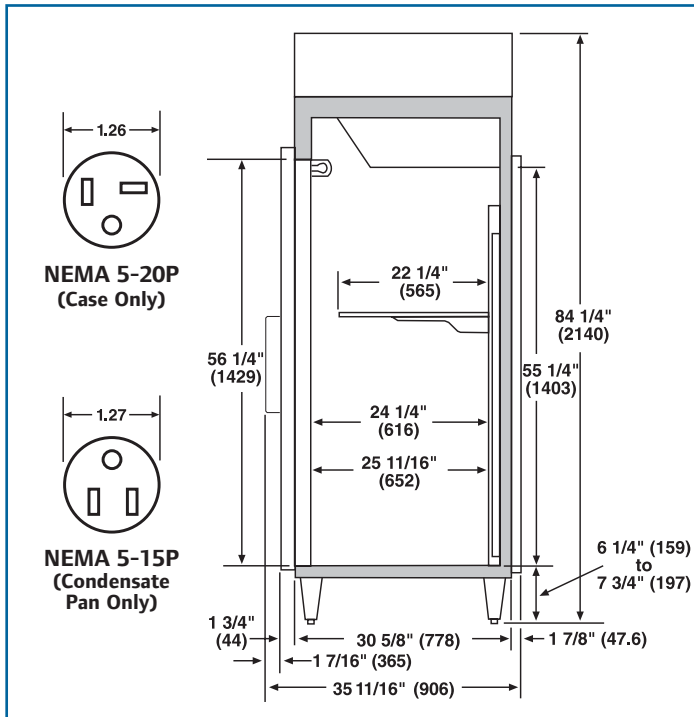

## Standard Features

- Rugged construction. Steel exteriors and interiors finished in white powder coated paint. CFC-free foamed-in-place urethane insulation for thermal efficiency and structural rigidity.
- Top mount unit. Heat and noise are directed up and away from work area. Condenser stays cleaner.
- Efficient ventilation. The ventilated front panel and open back design provide flow through cooling.
- Self-closing doors. All steel. Sturdy cam-lift hinges allow doors to stand open for stocking. Security door locks. Magnetic gaskets for positive door-to-cabinet seal.
- Cantilever shelves. Each door section has three adjustable cantilever-type shelves and a bottom rack. Powder coated for corrosion resistance and easy cleaning. Shelves are interchangeable with other 2- door and 3-door upright models.
- Automatic defrost. Cabinet interior is kept frost-free by an automatically controlled defrost system. No need for external drain. Condensate pan requires a separate 115V, 15 amp outlet.
- Adjustable legs. Each unit has six-inch adjustable legs to elevate cabinet off floor and maintain sanitation. Optional caster kits are available.
- Easy-to-read dial thermometer, in top panel, provides a quick check on interior temperatures in both Fahrenheit and Celsius scales.

## Specifications

Model	Cu. Ft. Caps.	Doors	Dimensions					
			Exterior			Interior		
			L	W*	H	L	W	H
USL-2	43.7	2	52"	34 1/4"	84 1/4"	47 13/16"	25 11/16"	62 3/4"

Model	Unit H.P.	Refrig. Type	Electrical				Ship Wt.
			Volts	LRA	Run Amps††	Fuse Amps	
USL-2	3/4	R-404A	115**	59.8	15.0	20	875

\*Exclusive of door handles. \*\*115V Power cord requires 20 amp receptacle. ††115V Condensate Pan uses 2.6 amps.



NOTE: For optimum performance, these models are designed for use in air-conditioned stores where temperature and humidity are maintained at 75°F and 55% R.H. Locate case away from direct sunlight, rapid air currents and extreme temperature changes.

We reserve the right to change or revise specifications and product design in connection with any feature of our products. Such changes do not entitle the buyer to corresponding changes, improvements, additions, or replacements for equipment previously sold or shipped.

## Warranty

Five years against insulation failure or leaks in insulated area. Five years against failure of compressor. One year against defective material or faulty workmanship, including labor.

**Hussmann Corporation**  
 140 East State Street  
 Gloversville, NY 12078  
 (518) 725-0644  
 (800) 753-7790  
 Fax: (518) 725-3801

**HUSSMANN®**

Web Site: [www.hussmann.com](http://www.hussmann.com)

