

HUSSMANN®

P2X

IMPACT EXCEL

Single or Multi-Deck Produce Merchandiser



Single or Multi-Deck Produce Merchandiser

P2X-E Single or Multi-Deck Produce
 P2X-EP Single or Multi-Deck Produce With E-Plus
 "Extra High Efficiency" Coil

HUSSMANN®
Impact Excel

All models available in 4', 6', 8' & 12' lengths.

**P2X-E
 P2X-EP**

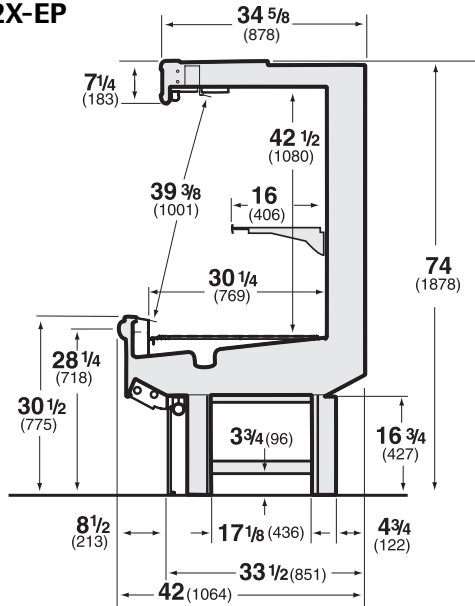

Note: Please use Hussmann's technical data sheets to get precise dimensions for all store layout purposes.

P2X-E, P2X-EP 4', 6', 8' & 12' Plan Views

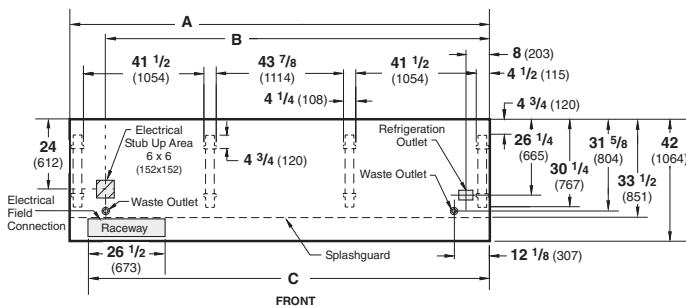

Dimension	A	B	C
4 foot	48 3/8 (1229)	36 1/4 (921)	42 1/8 (1070)
6 foot	72 3/8 (1838)	60 1/4 (1530)	66 1/8 (1680)
8 foot	96 3/8 (2448)	84 1/4 (2140)	90 1/8 (2289)
12 foot	144 1/2 (3670)	132 3/8 (3363)	138 1/4 (3511)

Note: Overall case length without ends or partitions

Superior Merchandising

The P2X creates an appealing wall of produce in both single and two deck configurations. Superior display features include full vision glass ends, illuminated canopy signs, improved ledge lighting and more.

Lower Energy Costs

Energy efficient "E" coils are standard on the P2X. The "highest efficiency" E-Plus coils are optional, reducing energy costs by about 18% compared to a standard Impact produce case. Optional night curtains will further reduce energy by about 12%.

Superior Shelf Life

Modular coils and off-time defrost work to reduce thermal shock and stabilize product temperatures, resulting in better freshness and longer shelf life. Modular defrost, optional, can further stabilize temperatures.

Lower Labor Costs

Labor saving features include greater clearance under the case, easy-to-clean bathtub bottom, adjustable feet, easier raceway access, 2' honeycomb sections and more.

Superior Reliability

Our five year modular coil warranty is the best available. Pre-set expansion valves are designed to hold optimal temperatures throughout the life of the case.

Note: These merchandisers are designed for use in stores when temperature and humidity do not exceed 75°F and 55% RH.

Note: We reserve the right to change or revise specifications and product design in connection with any feature of our products. Such changes do not entitle the buyer to corresponding changes, improvements, additions or replacements for equipment previously sold or shipped.

Web Site: www.hussmann.com
 E-mail: hussmann-marketing@irco.com

IR Ingersoll Rand
 Climate Control Technologies

Hussmann Corporation
 12999 St. Charles Rock Rd.
 Bridgeton, MO 63044-2483
 (314) 291-2000
 (314) 298-4756 Fax