

# HUSSmann®

HGM-3BS

*Self-Contained Vertical Glass Door Merchandisers*



# Self-Contained HGM Vertical Glass Door Merchandisers

# HUSSMANN®

HGM-1BS, HGM-2BS, HGM-3BS Bottom Mount Medium Temperature for Dairy, Deli and Beverages

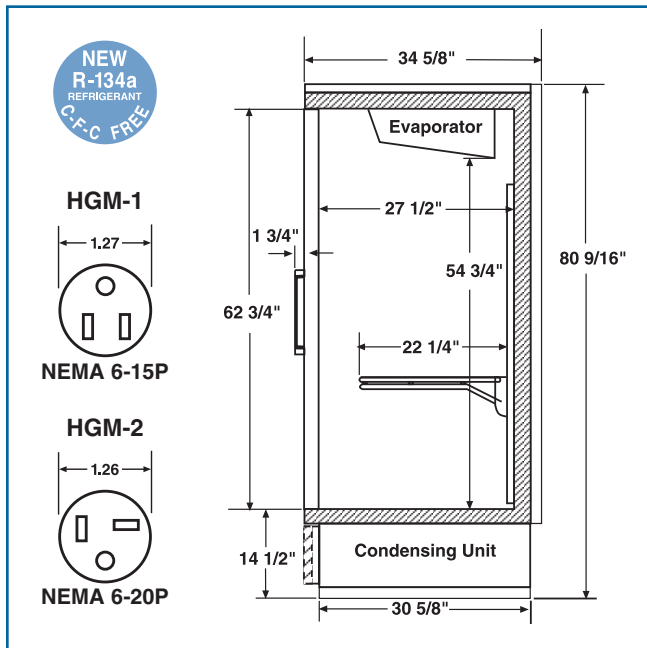

## Standard Features

- Contemporary styling of the Accent Series places maximum attention on merchandising. All Accent Series merchandisers have the same access panel design for commonality between merchandisers.
- Product visibility is improved with 60" long vertical T-8 lighting and electronic ballasts. Merchandise is evenly illuminated throughout display area. More lights per merchandiser with two lights in single-door, three-lights in two-door and four lights in three-door models.
- White powder coated exterior and interior finish.
- CFC-Free refrigerant R-134a and CFC-Free foamed-in-place urethane insulation.
- Doors can be locked open for stocking.
- Each door section includes four adjustable cantilever-type shelves and a bottom rack. All shelves and racks have a white epoxy coated finish. Shelves may be slanted for special displays and are interchangeable in all models.
- Full use of the shelf upright posts is available for positioning the shelves. Shelf bracket profiles have been slimmed down to better facilitate product merchandising under and across the shelves.
- The HGM-1BS and HGM-2BS are equipped with 115 volt power cord (see diagram). The HGM-3BS requires field wiring to 115 volt service.
- Easy-to-read digital solar powered thermometer. Electronic temperature control insures consistent product temperature.

## Optional Accessories

- Variety of Exterior Colors
- Three Tier Step Rack
- Price Tag Moulding
- Baskets
- Shelf Product Stops
- Additional Display Shelves
- Door Guard
- Peg Bar and Hooks
- End Windows
- Lighted Sign
- Defrost Timer
- Leveler Kit
- Can Dispensing Rack
- Caster Kit

## HGM-BS Optional Lighted Sign



## Matching Low Temperature Models

For a matching side-by-side display of frozen foods and ice cream, be sure to see the companion HGL-BS series of low temperature 1-, 2- and 3-door models.

## Warranty

Five years against insulation failure or leaks in insulated area. Five years against failure of compressor. One year against defective materials or faulty workmanship, including labor.

NOTE: For optimum performance, these models are designed for use in air-conditioned stores where temperature and humidity are maintained at 75°F and 55% R.H. Locate case away from direct sunlight, rapid air currents and extreme temperature changes.

We reserve the right to change or revise specifications and product design in connection with any feature of our products. Such changes do not entitle the buyer to corresponding changes, improvements, additions, or replacements for equipment previously sold or shipped.



Model	Cu. Ft. Cap.	Doors	Dimensions (Inches)						Electrical						Ship Wt.
			Outside			Inside			Unit H.P.	HZ/PH	Volts	Fuse Size	Power Cord	NEMA Plug Nos.	
			L	W*	H	L	W	H							
HGM-1BS	22.2	1	28 7/8"	34 5/8"	80 9/16"	24"	27 1/2"	62 3/4"	1/3	60/1	115	15 amp	Yes	5-15P	593
HGM-2BS	44.3	2	52"	34 5/8"	80 9/16"	48"	27 1/2"	62 3/4"	1/2	60/1	115	20 amp	Yes	5-20P	825
HGM-3BS	66.1	3	75 3/8"	34 5/8"	80 9/16"	71 1/4"	27 1/2"	62 3/4"	3/4	60/1	115	30 amp	No	N/A	1096

\*Exclusive of door handles. All use R-134a Refrigerant. Optional lighted sign increases overall height to 83 9/16".

Web Site: [www.hussmann.com](http://www.hussmann.com)  
1-800-922-1919

