

HUSSMANN[®]

FN

IMPACT EXCEL

Narrow Island Merchandiser for Frozen Food/Ice Cream



Narrow Island Merchandiser for Frozen Food/Ice Cream



FN-Narrow Island Merchandiser for Frozen Food/Ice Cream

Available in 8' & 12' lengths.

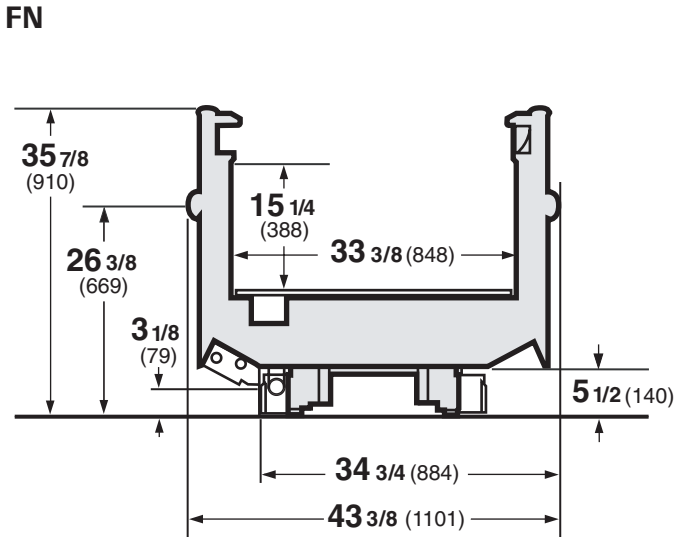

FN, FNG Plan View

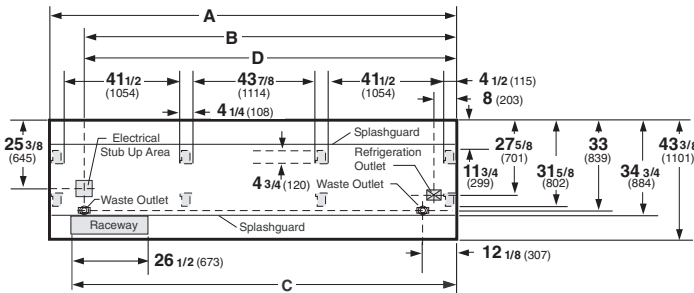

Dimension	A	B	C	D
8 FT CASE	96 3/8 (2448)	84 1/4 (2140)	90 1/8 (2289)	84 1/4 (2141)
12 FT CASE	144 1/2 (3670)	132 3/8 (3363)	138 1/4 (3511)	132 3/8 (3363)

Note: Please use Husmann's technical data sheets to get precise dimensions for all store layout purposes.

More Energy Efficient

The Impact Excel FN has improved energy efficiency compared to Impact and all competitive models.

More Merchandising Capacity

Compared with the standard Impact model, the Impact Excel FN narrow island provides 5% more merchandising space.

Superior Shelf Life

Excellent temperature consistency and stability throughout the display zone due to Husmann's proprietary discharge air louvers and continuous tube serpentine coils.

Lower Labor Costs

Labor saving features include greater clearance under the case, adjustable feet, easier raceway access and simplified wiring.

Superior Reliability

Our 5 year coil warranty is the best available. Pre-set expansion valves are designed to hold optimal temperatures throughout the life of the case.

Note: These merchandisers are designed for use in stores when temperature and humidity do not exceed 75°F and 55% RH.

Note: We reserve the right to change or revise specifications and product design in connection with any feature of our products. Such changes do not entitle the buyer to corresponding changes, improvements, additions or replacements for equipment previously sold or shipped.

Web Site: www.husmann.com
E-mail: husmann-marketing@irco.com



Husmann Corporation
12999 St. Charles Rock Rd.
Bridgeton, MO 63044-2483
(314) 291-2000
(314) 298-4756 Fax